

# **Social responsibility in B2B and its influence on long-term orientation through the trust**

## **Analysis in oil and petrochemical industry**

### **Abstract:**

Study examined the effects of three aspects of corporate social responsibility (CSR) (i.e., quality, Awareness, Attributions) and the main factor in marketing concept (Trust) on organizational long-term orientations in oil and petrochemical industry. Based on survey data collected from suppliers working with SABIC in Saudi Arabia, the relationships were examined using confirmatory factor analysis, second-order factor analysis, and structural equation modelling. The results indicate that the quality of CSR Activities is related to organizational long-term orientations in oil and petrochemical industry with the trust as a mediating variable, suggesting that adding CSR programs is likely to improve desirable suppliers to build a strong relation with SABIC, which in turn contributes to increasing the length of the relationships. This study contributes to the literature by conceptually and empirically evaluating the quality of CSR activities and trust dimensions simultaneously in oil and petrochemical industry.

**Key Words:** B2B, Corporate social responsibility CSR, Trust, Long term orientations.

### **Introduction:**

This paper highlights the relations in the context of marketing scientific research. many research streams are distinguished after a thorough analysis of scientific

literature, i.e. development and maintenance of sustainable relationships with suppliers; suppliers' responses to corporate socially responsible activity; strengthening corporate reputation; identification whether CSR may affect the process of supplier's decision making, the preferences of suppliers; CSR integration into marketing activity; maintain supplier's trust and establish long-term relationships. Results of analysis show that there are different approaches to investigate the effect of CSR on corporate results. However, from the marketing perspective, intangible results, such as long-term relationships between company and supplier could be described as a major benefit for company which integrates CSR in corporate activity.

Recently oil and petrochemical business has been facing challenges conditioned by dynamic changes in economic, technological, political and social environments. according to this speed movement companies search for means to ensure stability and to achieve long-term results, the CSR consider as an important concept that contributes to the achieve that results .The significance of this concept began to be realized since according to Carroll's (1991, 1998) give his definition with four CSR dimensions has been commonly adopted: a company should (1) make goods or services for consumers to yield a satisfactory profit in the process (economic responsibility), (2) comply with laws and regulations stated by governments in its operations (legal), (3) meet expectations of stakeholders and protect them regardless if these activities are not codified into law (ethical), and (4) meet stakeholders' expectations on the company's engagement to enhance human welfare or good will (philanthropic) . The importance of CSR stems from the interest of the firm to integrate social issues in order to ensure sustainable development. This process is based on the belief that implementing CSR actions provides a better assessment of the activity and thereby an improvement of corporate performance in the long term (de la Fuente & de Quevedo, 2003; Devine & Halpern, 2001)<sup>i</sup> In addition, the

company's engagement in socially responsible activity mitigates the consequences of economic crisis and helps to recover from it (Pirsch, Gupta & Grau, 2007)<sup>ii</sup> are confirmed by close relations between corporate social responsibility and sustainable development (Ellis & Bastin, 2011)<sup>iii</sup>.

## **Literature review:**

Before approaching the issue of the relationship between CSR and long-term orientation using trust as a mediator, we briefly discuss the concepts in accordance with the most relevant conceptual frameworks in the literature.

### ▪ **Conceptualization of CSR:**

Scientific discussions on the topic of CSR have been going on for more than five decades. There is no doubt that the works of (Carroll 1991, 1998, 2000), which define the structure of corporate socially responsible activity and are extensively analysed in subsequent studies, are considered to be the most significant sources of scientific literature that initiated the discussion about the decisions of CSR implementation in company's performance. Nevertheless, it should be noted that a lot of scientific works on CSR were to studies of CSR conceptualisation and estimation of its impact on corporate financial performance, the interest of marketing researchers in CSR mergetion into different areas of corporate activity served as an incentive for further development of CSR theory. but Despite the growing interest in this topic, there is still no general agreement on the precise meaning of CSR in B2B especially in oil and petrochemical industry.

literature appears that CSR in B2B especially oil and petrochemical companies are often engaging in CSR. For example, in 2011, the chemical company BASF invested €48.7 million solely for CSR activities outside its business operations in the form of philanthropic involvement (BASF 2012) and in 2018 SABIC invested \$36.5

million in community giving (SABIC annual report 2018) with high profits due to forefront of engaging in CSR activities.) Christian Homburg, Marcel Stierl, & Torsten Bornemann in their conceptual framework demonstrated that CSR engagement has positive effects, thus providing B2B companies with a justification for an active commitment to CSR-related issues. Consequently, CSR has relevance for businesses in two ways. First and the main challenge for corporations is to connect with society in such a way that the positive public image of the company is maintained and enforced. Most companies have a certain track record when it comes to CSR as perceived by stakeholders and society through past history and actions. Since the company is dependent on the society (where its customers and other stakeholders are), this track record should be protected and to the extent possible enhanced. Activities and actions directed at this objective can be labeled CSR enforcement. Second, whereas building and enforcing the level of CSR is a continuous long-term activity, the CSR reputation of the company can be severely affected by sudden critical events (i.e. CSR critical incidents)

Now SABIC as the largest oil and petrochemical company in the world has completed attention to social responsibility and the mission is backed by promise to the communities that serve and supported by these foundation principles:

- Commitment to develop long-term mutual beneficial partnerships with our communities.
- Work with and respect different cultures, values, traditions and preferences of our communities.
- Deliver CSR projects and programs in a way that bring both social and economic benefits to SABIC and its communities.
- Develop CSR programs with a sustainable approach without creating dependency.
- Monitor and measure, where possible, the outcomes of CSR programs and

identify areas of improvement for continued enhancement.

- Share information about our performance and activities that have a major impact on our communities.

- **The importance of long-term Orientation:**

To achieve competitive advantage through a strong and long relation with the suppliers in the future, companies with a long-term orientation often engage in activities that do not necessarily generate immediate revenues, such as investing in R&D and CSR (Brews and Purohit, 2007; Grant, 2003)<sup>iv</sup>.

Long-term effectiveness efficiency may not be mutually exclusive, its often reflect different strategic priorities and require different organizational processes (Hamel and Prahalad, 1989,1994)<sup>v</sup>.

In addition, companies with a long-term orientation can gain supplier's trust by making strategic decisions that better realize the benefits of CSR activities. A long-term orientation widens the company's field of vision, which enables the company to recognize the potential value of on economic revenues. As a result, companies with a long-term orientation tend to choose a strategy that will emphasize continuous innovation in the CSR activates.

(Hamel and Prahalad, 1989, 1994) argues that companies with a long-term orientation encourage the development of strategic resources that do not offer explicit short-term value allowing these companies to identify implicit value from complex suppliers' relationships built from CSR activities, as a result, CSR may attenuate negative impacts of reputation of the companies thus, can build a strong bridge with suppliers from CSR activities.

- **Trust:**

The literature in this field shows that trust is a prerequisite for the creation and preservation of long-term relationships between the company and its suppliers (Kantsperger & Kunz, 2010; Morgan & Hunt, 1994)<sup>vi</sup>, mainly in oil and petrochemical industry. (Reichheld and Schefter 2000)<sup>vii</sup> observe that to win suppliers' loyalty, firms must first win their trust. In fact, it is one of the key elements associated with service recovery (Choi & La, 2013)<sup>viii</sup> and it can be an important factor in suppliers' purchasing decisions. Furthermore, some studies find that trust is a strong determinant of loyalty and influences not only the outcomes such as a, commitment but also the processes of the relationship, such as the quality of the interaction (Hikkerova & Sahut, 2014; Moorman, Zaltman, & Deshpande, 1992)<sup>ix</sup>. Trust in a service provider is highly related to perceptions of service provider's integrity, honesty, confidentiality, and ethicality (Coulter and Coulter, 2002) <sup>x</sup> positive perceptions of CSR give rise to the favourable appraisal of consuming and favourable attitudes to companies (Sen & Bhattacharya, 2001)<sup>xi</sup>. Thus, companies that implement socially responsible practices obtain a higher degree of commitment from their customers and from society in general, and at the same time increase suppliers' trust. In this context, numerous studies have attempted to discover whether CSR activities contribute to improving the organization's efficacy through satisfaction with or trust in the organization (Hansen, Dunford, Boss, Boss, & Angermeier, 2011; Valentine & Fleischman, 2007)<sup>xii</sup>. The results of a survey of CEOs at the Business Roundtable Institute for Corporate Ethics (2004)<sup>xiii</sup> indicate that one of top issues in corporate ethics is related the need to regain customers trust. Consistent with the survey results, (Paine 2000)<sup>xiv</sup> states that adherence to ethical standards especially in the activates of CSR provides the basis for trust, helps to build reputation, and it's important to maintain the relationships to

meets a future vision. In a similar line, quality and awareness of CSR activates has a positive impact on customer trust in the firm. The effectiveness of CSR activities is often very difficult to measure on the long term. So, the customer perceptions that a company is socially oriented are associated with a higher level of trust in that company and its products.

Furthermore, (Mobin Fatma 2014)<sup>xv</sup> provide a conceptual framework for CSR and trust in corporate relationships, arguing that CSR affect trust. Hence, we propose that the aspect of perceived CSR has a positive impact on customer trust in the oil and petrochemical companies. Therefore, we hypothesize that:

**H1: CSR Quality has a direct significant effect on long-term orientation**

**H2: CSR quality has a significant effect on trust**

**H3: Trust has a significant effect on long-term orientation**

### **The mediating effects of supplier's trust:**

Major reviews of CSR-long term orientations relationship agree that reputation and supplier's trust relate positively to long term orientations. We cannot ignore the fact that a positive relationship has been found between supplier's trust and reputation (Walsh et al., 2006, 2009; Wang et al., 2003)<sup>xvi</sup>. The reputation is the key reason for this relationship and its core, is a result of past actions that demonstrate to stakeholder's information about how well a company meets its commitments and conforms to their expectations (Brown and Logsdon, 1999)<sup>xvii</sup>. As such, when developed well, reputation becomes one of a firm's most strategic resources (Flanagan and O'Shaughnessy, 2005)<sup>xviii</sup>. Further, Nguyen and Leblanc (2001)<sup>xix</sup> argue that a positive reputation is one of the most reliable indicators of whether or not a firm's customers are satisfied.

The reputation of the company in the scope of our research comes through the

effective awareness of suppliers about the activities of social responsibility and the quality of these activities plus their trust.

Therefore, as trust strength increases, the positive relationship between CSR and long-term orientation (Hypothesis 3) will increase in its magnitude, if CSR activates is strong enough. but differently, A trust can be considered a positive factor that alters or reverses the relationship between CSR and long-term orientations. The relationship between CSR activities and long-term orientation is positively moderated by trust between companies and suppliers.

**H4: Trust plays a significant role as a mediator factor between CSR Quality and long-term orientation**

### Research methodology:

- **Conceptual Framework:**

**Figure1:** The influences of CSR and trust on long-term orientation

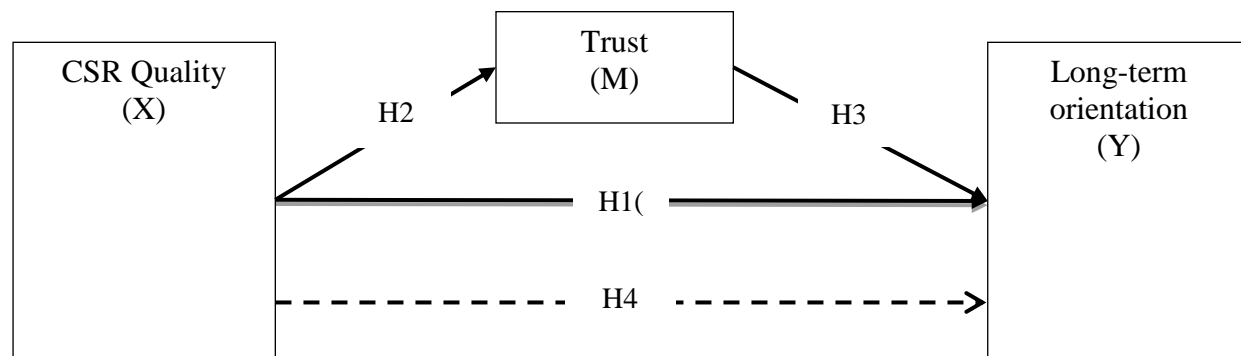

**Figure1:** Shows a path diagram for the causal relationships between the three variables CSR, trust and long-term orientation. In mediation models that consist of one independent variable, one mediator, and one final outcome variable, the effect of the independent variable CSR (X) on the final outcome variable long-term orientation (Y) can be divided into two effects: the



direct effect H1; and the indirect effect H4, which is the product of the direct effects H2 (CSR Quality – Trust) and H3 (Trust – Long term orientation). There are two types of mediation: partial mediation occurs when the direct effect H1 is different from zero and the same sign as the mediating effect (H2,H3); complete mediation occurs when the direct effect H4 is not substantial in size (Baron & Kenny, 1986)<sup>xx</sup> In addition, the model includes several variables of control that have proved to be important in this process. such as: sector’s activity of the suppliers, companies’ size, the contractual relationship with SABIC and the country of origin. The relationship of variables of control with CSR, trust and long-term orientation in the sense theoretically expected provide consistency and validity to the model. (Table1)

**Table 1.** Demographic and suppliers -related variables considered in the research.

<b>Variables</b>	<b>Percentage (%)</b>
<b>Sector’s activity</b>	
Primary sector (include agriculture, mining, forestry	4.51
Secondary sector (include metal working and smelting, automobile production	68.31
Tertiary sector includes retail and wholesale sales, transportation and distribution	18.4
Quaternary sector includes government, culture, libraries, scientific research, education	8.78
<b>Country of Origin</b>	
Europe	30.7
USA	21.4
Asia	23.0
MENA	24.9
<b>Number of employees</b>	
<2000	31.1
<5000	58.1
<10,000	10.8
<b>Duration of the contract</b>	
0-5 years	19.7
6-10 years	23.6
11-20 years	33.1
Greater than 20 years	23.6

- **Measurement development:**

Measures of constructs were developed and adapted on the basis of extant literature (the scale items are listed in the appendix) we drew on the studies of (Lankoski 2009, Wagner, Lutz, and Weitz 2009) to measure the CSR dimensions. In addition, trust measures were adapted from (Sanzo et al. 2003) Which is conceptualized and measured in different ways and, covers diverse aspects, such as credibility, trustworthiness, honesty and benevolence. We measured long-term orientation that was validated in prior research (Miller and Friesen, 1982; Venkatraman, 1989).

- **The Sample:**

We start with communication with the CEO's office to build a partnership between SABIC and Lille university to make this partnership as a good source to build mutual benefits from this study.

This study with the survey content is aligned with the PhD topics and tailor-fitted to SABIC partners' businesses and collaborations and their experience with SABIC, they received a clear and professional questionnaire with 300 questioners in the field of branding and CSR, the feedback received from more than 46 different countries in different regions (Europe, America, Africa and Asia).

We received a huge bulk of data from SABIC global partners, we then injected it to the AMOS engine to receive a different variable report, this is to measure the relationship using different parameters (branding, CSR, Business growth and reputations). All of the measures used in this study were drawn from existing literature and adapted to the context of the current study. The measurement scales were 7-point scale ranging from 1 (Strongly Disagree) to 7 (Strongly Agree). Therefore, using a survey to collect data for new ventures' long-term orientation and financial performance was not only practical but also appropriate.

## **Steps:**

1. Get Directions from the mentor.
2. Obtain Approval from the SABIC CEO.
3. Ask Guidance from the SABIC CC VP.
4. Secure a Commitment from the SABIC CSR Director.
5. Review the contents with the SABIC CSR Specialist and Legal department.
6. Get an Agreement from SABIC P&SC GM.
7. Release the survey by SABIC P&SC Planner.
8. Receiving the feedback and collecting the data.
9. Use the SPSS (Amos) software to analyse the collected data.

## ▪ **Measures:**

Based on the chosen literature, we selected measurement items that appropriate for the present study. We utilized measurement items used in the existing literature. Either the exact measurement items presented in previous research were used, or they were adjusted as necessary to measure the latent constructs. All measures used are shown in Appendix. The suppliers were asked to respond using a seven-point Likert scale ranging from 1 (strongly disagree) to 7 (strongly agree).

## ▪ **Data Analysis:**

The covariance-based estimation methods are more appropriate in situations where the theoretical knowledge is solid and the research aim is to extend development and evaluation of the theory. In contrast, when the theoretical knowledge is scarcer such as our study the research goals are predictive and the model to estimate is more complex, the AMOS technique is considered more appropriate. The main reason for using AMOS is, therefore, to find out whether the theoretical concepts are measured correctly through the variables observed.

We used the mediation in our model when an independent variable affects an outcome variable through a third variable, called mediator which is trust, so trust consider as a main concept in business takes part in many mediating relationships.

- **Model Fit:**

The measures of absolute fit of the model estimated present values within the recommended limits. The study used confirmatory factor analysis (CFA) to verify the measurement model. The hypothesis of adequacy between the proposed model and the data used is supported. Moreover, the results obtained from the incremental fit measurements are also acceptable since the value.

## First order:

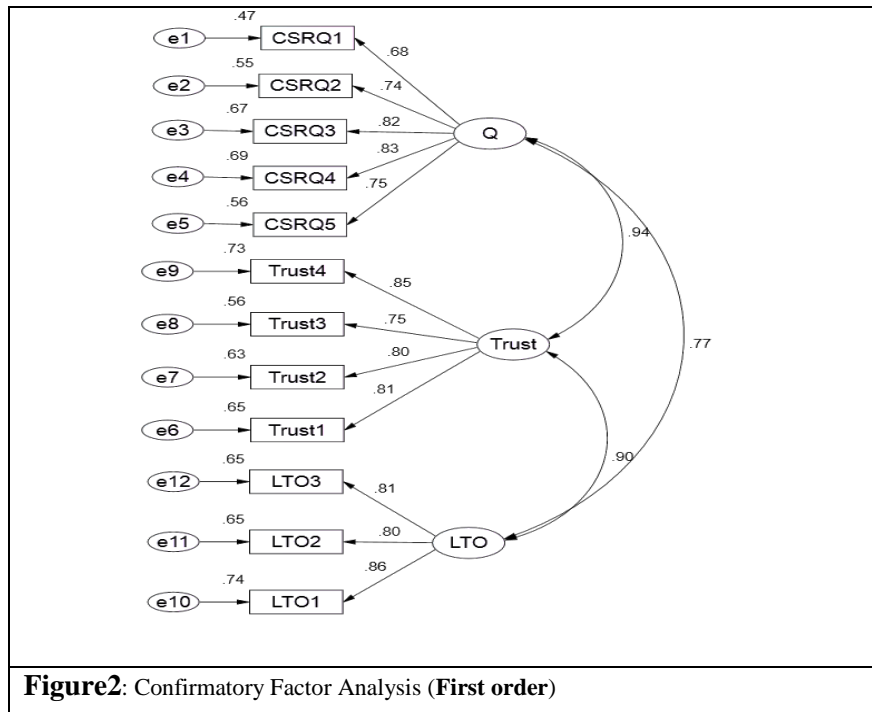

**Table 2:**

CFA Fit Indices (First order)				
Categories of Model Fit	Name of index	Level of acceptance Reference <sup>(1)</sup> & <sup>(2)</sup> Zainudin (2012) & Hair et al (2010)	Fit Indices	Result
Absolute Fit	Chi-Square ( $\chi^2$ )	P-value more than 0.05	.000	Acceptable in the case of sample size is large (normally more than 200) <b>Zainudin (2012)</b>
	RMSEA	Less than 0.08	.083	<b>Poor fit</b>
	GFI	More than 0.90	.918	Good fit
Incremental Fit	AGFI	More than 0.90	.875	<b>Poor fit</b>
	CFI	More than 0.90	.967	Good fit
	TLI	More than 0.90	.956	Good fit
	NFI	More than 0.90	.948	Good fit
Parsimonious Fit	$\chi^2/df$	Less than 3.0	3.059	<b>Not a unique model</b>

From the (Table2), the results of the first analysis of the global empirical analysis show CFA (first Order)

<sup>1</sup> Awang, Zainudin. "A handbook on structural equation modeling using AMOS." (2012).

<sup>2</sup> Hair, J. F., Black, W. C., Babin, B. J., & Anderson, R. E. (2010). *Multivariate data analysis* (7th ed.). Upper Saddle River, NJ: Pearson Prentice Hall.

The RMSEA value is .083 higher than 0.08, while the AGFI value 0.875 lower than 0.90, in addition  $\chi^2/df$  valued by 3.059 higher than 3.0, based on (Zainudin hair et al 2010) opinion We found that this module is not applicable with Poor Fit module, this requires an improvement of the model by revising modification index. These values can be explained on below table.

**Table3:**

<b>Modification Indices (First order)</b>			
		M.I.	Par Change
<i>e10</i>	<--> <i>e9</i>	<b>27.366</b>	<b>.117</b>
e8	<--> e5	18.913	.231
e8	<--> e10	13.501	-.127
<i>e7</i>	<--> <i>e8</i>	<b>20.746</b>	<b>.198</b>

From the previous result (Table3), the values of the covariance between (e10 and e9); and (e7 and e8) are relatively high. This cause poor fit for the model, so If the covariance between e7 and e8 as a free parameter are treated, the discrepancy will fall by at least 20.746.

From the other side, the covariance between e10 and e9 is related to two different variables (Trust and Long-term orientation). Therefore, covariance between e10 and e9 can't be treated. So, by dispensing the factor Trust4, the discrepancy will fall by at least 27.366.

## Second order:

In the second order model modifications were done as a process for enhancing the model fit. The second order of CFA will be illustrated as follow:

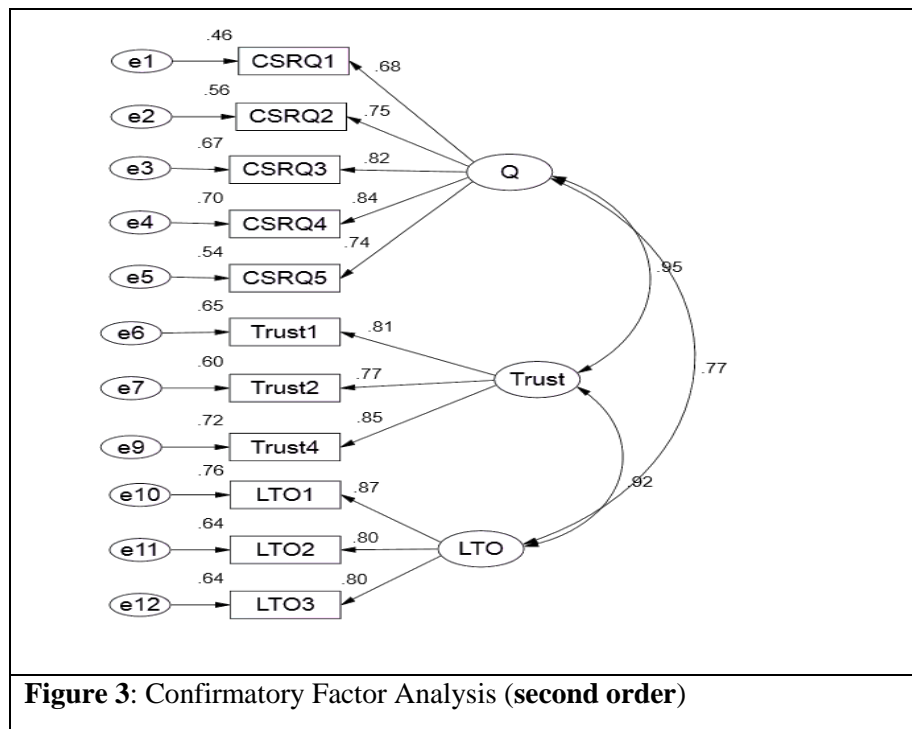

**Factor loadings:** Correlation between the original variables and the factors, and the key to understanding the underlying nature of a particular factor. And its describes how variance ( $R^2$ ) is accounted for by the latent variable (Wang, Jichuan, and Xiaoqian Wang2012)<sup>xxi</sup>.

The Quality factor loadings were more than 0.5, which were (0.68, 0.75, 0.82, 0.84, and 0.74) in sequence. On the other hand, the Trust factor loadings were also more than 0.5, which were (0.81, 0.77, and 0.85) in sequence. Similarly, the Long-

Term Orientation factor loadings were also more than 0.5, which were (0.87, 0.80, and 0.80) in sequence.

**Table4:**

<b>CFA Fit Indices (second order)</b>				
Categories Of Model Fit	Name of index	Level of acceptance <sup>3</sup>	Fit Indices	Result
Absolute Fit	Chi-Square ( $\chi^2$ )	P-value more than 0.05	.000	Acceptable in the case of large sample size (normally more than 200) <b>Zainudin (2012)</b>
	RMSEA	Less than 0.08	.065	Good fit
	GFI	More than 0.90	.947	Good fit
Incremental Fit	AGFI	More than 0.90	.915	Good fit
	CFI	More than 0.90	.977	Good fit
	TLI	More than 0.90	.969	Good fit
	NFI	More than 0.90	.959	Good fit
Parsimonious Fit	$\chi^2/df$	Less than 3.0	2.273	Unique Model

### **The absolute fit**

is the acceptance guide for the model that determines the validity of the model and its suitability for research, and the most important used in this test is:

- P-value for Chi-Square ( $\chi^2$ ) which is should be  $> 0.05$
- The root means square error of approximation RMSEA which should be  $< 0.08$
- Goodness of Fit Index (GFI) which is should be  $> 0.09$

The results in (table 4) indicate that absolute fit acceptance factors were represented in:

- P-value for Chi-Square ( $\chi^2$ ) = .000 and it suppose be  $> 0.05$  but ( Zainudin 2012 )  
Indicates that in the presence of a large sample sizes in our search (300 sample ) it is possible to accept this value because it is less than 0.001 .
- Root mean square error of approximation (RMSEA) = 0.056
- Goodness of fit (GFI) = .947

---

<sup>3</sup> Awang, Zainudin. "A handbook on structural equation modeling using AMOS." (2012), Hair, J. F., Black, W. C., Babin, B. J., & Anderson, R. E. (2010). Multivariate data analysis (7th ed.). Upper Saddle River, NJ: Pearson Prentice Hall.



Based on the three factors we can say that the Absolute Fit is acceptable for the model.

**Incremental Fit:**

This analysis indicates the increasing acceptance of the general framework of the study and the most important concepts in this test is:

- Adjusted Goodness of Fit Index (AGFI)
- The Comparative Fit Index (CFI)
- The Tucker-Lewis Coefficient (TLC)

Which all of them should be higher than 0.9.

AGFI	CFI	TLC	NFI
.915	.977	.969	.959

Based on these results we can say that the Incremental Fit is also suitable for the study.

**Parsimonious Fit**

This section indicates that the model is fully accepted at the level where the value of ( $\chi^2/df$ ) lower than 3.0 , and from the previous Table ( $\chi^2/df$ ) reached to 2.273 which is the minimum discrepancy and therefore we can say that the Parsimonious Fit is the most acceptable category for the study.

## Structural model analysis:

In the structural analysis of the model, the modeling analysis was used in the structural equation modeling between the three variables (quality, confidence, long-term trend) as shown in the below figure4.

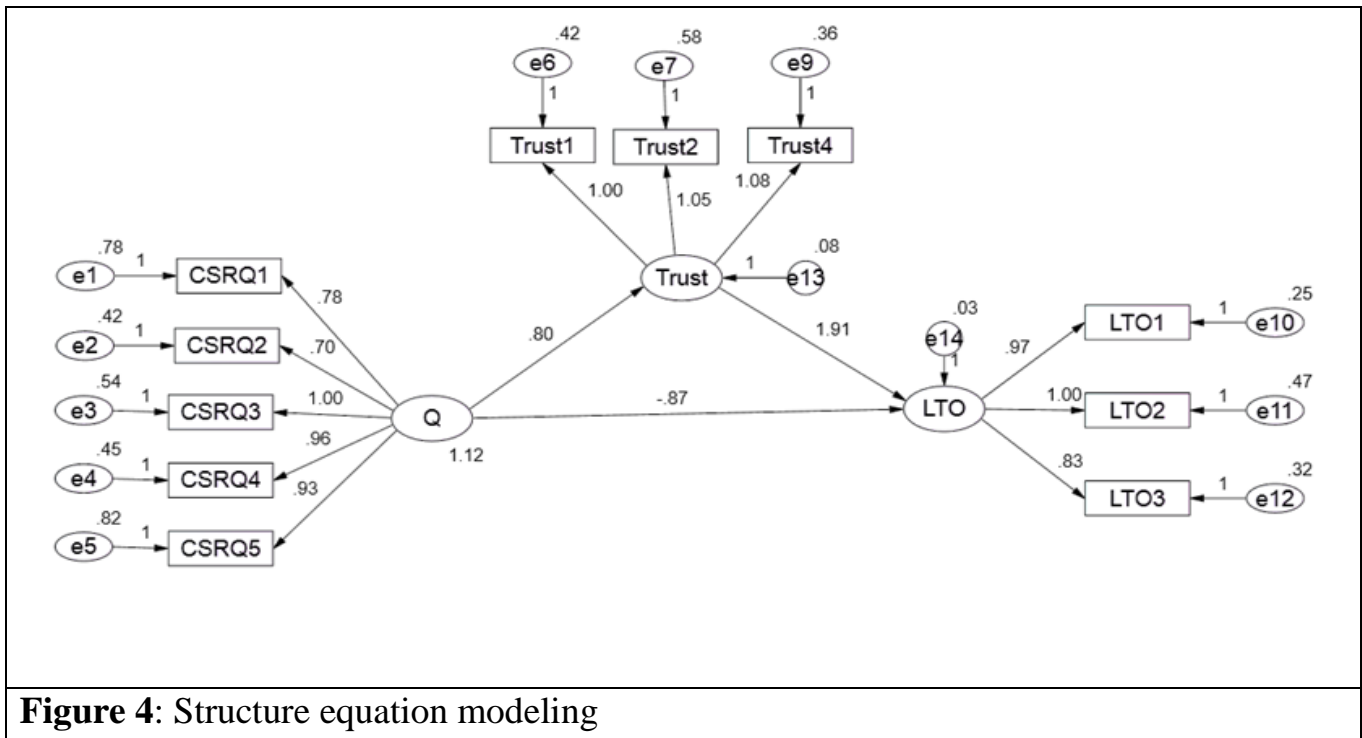

**Figure 4:** Structure equation modeling

### H1 test: CSR has a direct significant effect on long-term orientation

In order to test this hypothesis, we relied on the analysis of the structural equation modeling. The results of the test were as follows:

	Regression Weights				Standardized Total Effects	
	Estimate	S.E.	C.R.	P	Estimate	P
CSR ---> LTO	-.865	.382	-2.262	.024	.769	.014

Where the P value = .024, which is less than 0.05, which indicates rejection of the null hypothesis and acceptance the alternative hypothesis that indicates that CSR has a direct effect on long-term orientation, however the increase of one unit in CSR lead to change in LTO by (-.865).

According to the Standardized Total Effects, the dependent variable LTO effected significantly by (.769) for each increment by one unit in independent variable CSR.

**H2 test: CSR quality has a significant effect on trust**

In order to test this hypothesis, we relied on the analysis of the structural equation modeling. The results of the test were as follows:

	Regression Weights				Standardized Total Effects	
	Estimate	S.E.	C.R.	P	Estimate	P
CSR ---> Trust	.798	.053	15.135	***	.946	.005

Where the P value = .000, which is less than 0.05, which indicates rejection of the null hypothesis and acceptance of the alternative hypothesis that indicates a direct effect that CSR has a significant effect on Trust ‘ however the increase of one unit in CSR lead to change in Trust by (.798).

According to the Standardized Total Effects, the mediator variable Trust affected significantly by (.946) for each increment by one unit in independent variable CSR.

### H3 test: Trust has a significant effect on long-term orientation

In order to test this hypothesis, we relied on the analysis of the structural equation modeling. The results of the test were as follows:

	Regression Weights				Standardized Total Effects	
	Estimate	S.E.	C.R.	P	Estimate	P
Trust ---> LTO	1.914	.469	4.083	***	1.873	.006

Where the P value = .000, which is less than 0.05, which indicates rejection of the null hypothesis and acceptance of the alternative hypothesis that indicates a direct effect that Trust has a significant effect on LTO ‘ however the increase of one unit in Trust lead to change in LTO values by (1.914).

According to the Standardized Total Effects, the dependent variable LTO affected significantly by (1.873) for each increment by one unit in mediator variable Trust.

### H4 test: Trust plays a significant role as mediator factor between CSR quality and Long-term Orientation

In order to test the mediator variable Trust we have to test the direct and indirect effect between CSR and LTO and the results of the test were as follows:

	Standardized Indirect Effects					
	Q		Trust		LTO	
	Estimate	P	Estimate	P	Estimate	P
Trust	.000	...	.000	...	.000	...
LTO	1.772	.005	.000	...	.000	...

The results show a significant indirect effect between the independent variable CSR and dependent variable LTO.

Where the P value = 0.005, which is less than 0.05 which indicate the indirect effect

of the trust by (1.772) however the increase of one unit in CSR will increase indirectly on LTO by (1.772) based on the Trust.

Since the relationship between the independent CSR and the dependent LTO variable was significant ( $P=0.024$ ) (first hypothesis) this means that Trust plays a partial mediation role the relation between the independent and the dependent variables.

## Conclusion:

This study contributes to the literature both theoretically and empirically, since the aim of our research was to shed new light on the relationship between CSR and trust, long term orientation, analyzing the mediating role of trust. Additionally, it suggests a series of actions that oil and petrochemical companies (SABIC) follow in order to increase the positive effects of these variables. Our reasons for pursuing this goal were twofold: first, because of the importance of relations in oil and petrochemical companies, and second, because of the importance of CSR activities in this industry. Moreover, this study makes several contributions to the literature on CSR and suppliers' trust. Suppliers' awareness of social and environmental issues has been increasing (Brown and Dacin, 1997; Luo and Bhattacharya, 2006)<sup>xxii</sup>, suggesting emerging opportunities that can be pursued through CSR activities. In turn, enhances customer loyalty to firms (Gundlach and Murphy, 1993)<sup>xxiii</sup>. Previous research reported that CSR influence consumer product responses, customer-company identification (Sen and Bhattacharya, 2001)<sup>xxiv</sup>, customers' product attitude, and even a firm's market value (Luo and Bhattacharya, 2006)<sup>xxv</sup>. For this reason, oil and petrochemical companies carry out or source market research, undertake surveys, and analyze complaints in order to identify their suppliers' needs and satisfy them to the best of their abilities. However, despite the recognized importance of CSR and its effects on the development of trust with suppliers, the impact through trust continues to receive little research attention. Indeed, the existing literature focuses on the direct effects of CSR on the supplier's trust, but to a large extent ignores the indirect effects of and between these variables.

From a practical perspective, suppliers are believing that responsible companies operate honestly in their CSR activities are more willing to contract with companies

that develop socially responsible initiatives. Therefore, a CSR approach provides an efficient tool with which to increase the trust between companies and their suppliers. Therefore, our findings do suggest that long-term orientation in oil and petrochemical companies help to potential fuel new CSR activities, offers the opportunity to light on it and improving our understanding of the conditions and contexts that will allow business and relations to work perfectly. In addition, our result suggest that trust plays an important role as a mediating variable in CSR and long-term orientation. Finally, we demonstrate that while research on the direct relationship between CSR activities and trust could be useful a business case for CSR can be built on a different way as the companies can assessed their business performance by correlate with CSR.

## Reference:

---

- <sup>i</sup> De la Fuente, J. M., & de Quevedo Puente, E. (2003). Empirical analysis of the relationship between corporate reputation and financial performance: A survey of the literature. *Corporate Reputation Review*, 6(2), 161-177
- ii Pirsch, J., Gupta, S. & Grau, S. L. (2007). A Framework for Understanding Corporate Social Responsibility Programs as a Continuum: An Exploratory Study. *Journal of Business Ethics*, No. 70, p. 125-140
- iii Ellis, L. & Bastin, C. (2011). Corporate Social Responsibility in Times of Recession: Changing Discourses and Implications for Policy in Practice. *Corporate Social Responsibility and Environmental Management*, No. 19, p. 294-305.
- iv Brews P, Purohit D. 2007. Strategic planning in unstable environments. *Long Range Planning* 40(1): 64 – 83.
- v Hamel G, Prahalad CK. 1989. Strategic intent. *Harvard Business Review* 67 (3): 63 – 76.
- vi Kantsperger, R., & Kunz, W. H. (2010). Consumer trust in service companies: A multiple mediating analysis. *Managing Service Quality: An International Journal*, 20(1), 4–25.
- <sup>vii</sup> Reichheld, F., & Schefter, P. (2000). E-Loyalty: Your secret weapon on the web. *Harvard Business Review*, 78(4), 105–113.
- <sup>viii</sup> Choi, B., & La, S. (2013). The impact of corporate social responsibility (CRSR) and customer trust on the restoration of loyalty after service failure and recovery. *Journal of Services Marketing*, 27(3), 223–233.
- <sup>ix</sup> Hikkerova, L., & Sahut, J.-M. (2014). The effectiveness of loyalty programs in the hospitality industry: The case of hotels in Slovakia (Working Papers Series, 2014-127), Paris, France: Ipag Business School.
- <sup>x</sup> Coulter, K.S. and Coulter, R.A. (2002), “Determinants of trust in a service provider: the moderating role of length of relationship”, *Journal of Services Marketing*, Vol. 16 No. 1, pp. 35-50.
- <sup>xi</sup> Sen, S., & Bhattacharya, C. B. (2001). Does doing good always lead to doing better? Consumer reactions to corporate social responsibility. *Journal of Marketing Research*, 38(2), 225–243.
- <sup>xii</sup> Hansen, S. D., Dunford, B. B., Boss, A. D., Boss, R. W., & Angermeier, I. (2011). Corporate social responsibility and the benefits of employee trust: A cross-disciplinary perspective. *Journal of Business Ethics*, 102(1), 29–45.
- <sup>xiii</sup> Business Roundtable Institute for Corporate Ethics (2004), available at: [www.corporate-ethics.org/pdf/BRI-1001.pdf](http://www.corporate-ethics.org/pdf/BRI-1001.pdf)  
Carroll, A.B. (1991), “Corporate social performance measurement: a comment on methods for evaluating an elusive construct”, in Post, L.E. (Ed.), *Research in Corporate Social Performance and Policy*, Vol. 12, pp. 385-401.
- xiv Paine, L.S. (2000), “Does ethics pay”, *Business Ethics Quarterly*, Vol. 10 No. 1, pp. 319-330
- xv Mobin Fatma, Zillur Rahman and Imran Khan “Building company reputation and brand equity through CSR: the mediating role of trust”.
- xvi Walsh G, Dinnie K and Wiedmann K-P (2006) How do corporate reputation and customer satisfaction impact customer defection? A study of private energy customers in Germany. *Journal of Services Marketing* 20: 412–420.



---

xvii Brown TJ and Logsdon JM (1999) Corporate reputation and organization identity as constructs for business and society research. In: Wood DJ and Windsor D (eds) IABS proceedings (Tenth annual conference). Paris: International Association for Business and Society, pp. 168–173.

xviii Flanagan DJ and O'Shaughnessy KC (2005) The effect of layoffs on firm reputation. *Journal of Management* 31: 445–463.

xix Nguyen N and Leblanc G (2001) Corporate image and corporate reputation in consumers' retention decision in services. *Journal of Retailing and Consumer Services* 8: 227–236.

xx Baron, R. M., & Kenny, D. A. (1986). The moderator-mediator variable distinction in social psychological research: Conceptual, strategic and statistical considerations. *Journal of Personality and Social Psychology*, 51(6), 1173-1182

xxi Wang, Jichuan, and Xiaoqian Wang(2012)xxi. *Structural equation modeling: Applications using Mplus*. John Wiley & Sons, 2012

xxii Brown TJ, Dacin PA. 1997. The company and the product: corporate associations and consumer product responses. *Journal of Marketing* 61(1): 68–84

xxiii Gundlach, G.T. and Murphy, P.E. (1993), "Ethical and legal foundations of relational marketing exchanges", *Journal of Marketing*, Vol. 57, October, pp. 35-46 .

xxiv Sen, S., & Bhattacharya, C. B. (2001). Does doing good always lead to doing better? Consumer reactions to corporate social responsibility. *Journal of Marketing Research*, 38(2), 225–243

xxv Luo, X. and Bhattacharya, C.B. (2006), "Corporate social responsibility, customer satisfaction, and market value", *Journal of Marketing*, Vol. 70, October, pp. 1-18